

PennEngineering®

SELF-LOCATING
PROJECTION WELD NUTS



BULLETIN

WN



710
REV 112

SELF-LOCATING PROJECTION WELD NUTS

PEM® weld nuts (Types WN/WNS) provide load-bearing threads in metal sheets too thin to tap, and permit faster assembly.

PEM brand weld nuts overcome many problems associated with other weld nuts – burn-outs, complicated electrodes and pilots, tedious time-consuming indexing and re-tapping to remove weld spatter. Their design, based on the experience of hundreds of users of weld nuts, speeds production using standard equipment, thereby reducing labor costs.

PEM stainless steel weld nuts offer the added advantage of resisting corrosion. You may specify steel or stainless steel for your requirements and be sure you are getting the weld nuts that are easiest to install.

A variety of welding equipment is suitable for installation of PEM weld nuts. Best results have been obtained with a 50KVA press-type, spot-welding machine whose upper welding head moves vertically in a straight line with the lower electrode. Flat-faced electrodes with tip diameters .125" / 3.2 mm larger than the "E" dimension of the PEM weld nut should be used.

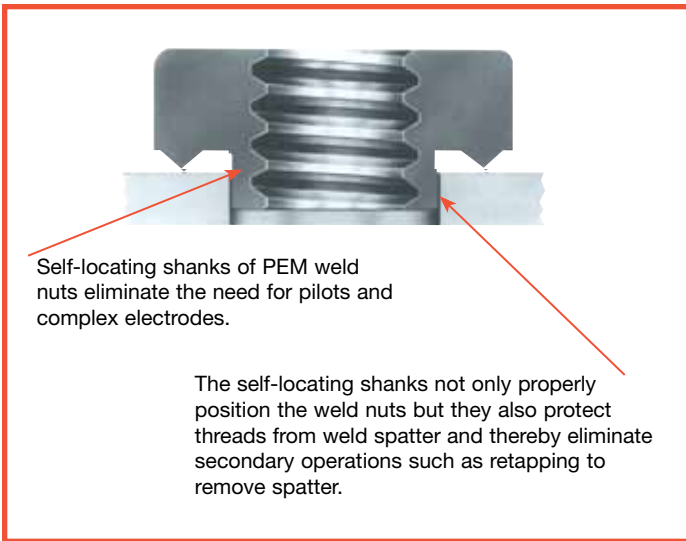

Round head of PEM brand weld nuts eliminates tedious, time-consuming indexing. Compact PEM weld nuts fit on narrow flanges.

The engineered projections of PEM weld nuts prevent burn-outs in thin sheets

Look for the PEM trademark on all cataloged sizes.



PART NUMBER DESIGNATION

WN S - 632 - 0
WN - - 632 - 0 CU

↓ Type ↓ Fastener Material Code ↓ Thread Code ↓ Shank Code ↓ Finish Code:
None on stainless steel nuts
CU on steel nuts (standard)

S = 300 series stainless steel
None = Carbon steel



SELF-LOCATING PROJECTION WELD NUTS

FASTENER MATERIAL:

Type WN – Carbon Steel
Type WNS– 300 Series Stainless Steel

FINISH:

Type WN – CU - Copper Flash
Type WNS– Passivated and/or tested per ASTM A380

THREADS:

Internal, ASME B1.1, 2B / ASME B1.13M, 6H

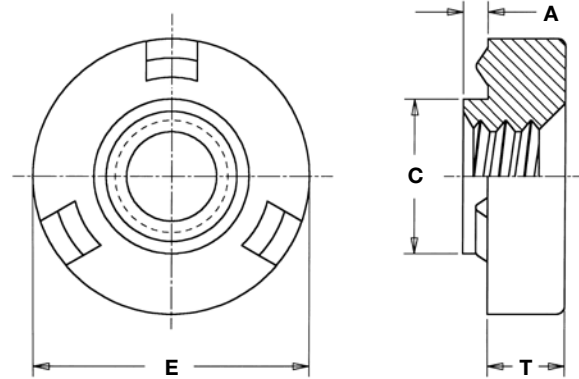

All dimensions are in inches.

UNIFIED	Thread Size	Type		Thread Code	Shank Code	A (Shank) Max.	Min. Sheet Thickness	Hole Size In Sheet +.004 -.000	C Max.	E +.000 -.010	T ±.004	Min. Dist. Hole \varnothing To Edge
		Steel	Stainless Steel									
	.112-40 (#4-40)	WN	WNS	440	0	.030	.030	.173	.172	.308	.065	.154
	.138-32 (#6-32)	WN	WNS	632	0	.030	.030	.193	.192	.341	.094	.171
	.164-32 (#8-32)	WN	WNS	832	0	.030	.030	.218	.217	.371	.108	.186
	.190-24 (#10-24)	WN	WNS	024	0	.030	.030	.250	.249	.440	.156	.220
	.190-32 (#10-32)	WN	WNS	032	0	.030	.030	.250	.249	.440	.156	.220
	.250-20 (1/4-20)	WN	WNS	0420	0	.048	.048	.316	.315	.522	.186	.261

All dimensions are in millimeters.

METRIC	Thread Size x Pitch	Type		Thread Code	Shank Code	A (Shank) Max.	Min. Sheet Thickness	Hole Size In Sheet +0.1	C Max.	E -0.25	T ±0.1	Min. Dist. Hole \varnothing To Edge
		Steel	Stainless Steel									
	M3 x 0.5	WN	WNS	M3	0	0.77	0.77	4.39	4.36	7.82	1.49	3.91
	M4 x 0.7	WN	WNS	M4	0	0.77	0.77	5.53	5.5	9.42	2.58	4.71
	M5 x 0.8	WN	WNS	M5	0	0.77	0.77	6.35	6.32	11.17	3.78	5.59
	M6 x 1	WN	WNS	M6	0	1.22	1.24	8.04	8.01	13.25	4.56	6.63

INSTALLATION

1. With a PEM weld nut inserted in the properly sized hole (see above), bring the electrode force up sufficiently to clamp the projections of the fastener firmly against the sheet without embedding any portion of the projections. Be sure the electrodes are centered, and that the electrode faces are flat so that the force is applied evenly to all three projections.
2. Set the current or heat regulator on the low side and adjust along with the weld time until a good weld is produced. For mild steel, which has a medium electrical resistance, there is a wide range of adjustments possible. For austenitic stainless steel, which has a high electrical resistance, the range is narrow at low heat.
3. Adjust squeeze time so that there is adequate time for the electrodes to close and develop proper forces (suggested initial setting 35 cycles). The weld period should be established by starting with the settings suggested in the tables on page WN-4. As indicated above for current adjustments, a wide range of time is possible with mild steel, but there is a limited range with stainless steel. If weld time starts too soon, and proper welding is not achieved, the squeeze time should be lengthened. Also, the electrodes should be moved closer together so that they require less travel time to close on the work. Longer squeeze times will have no effect on the quality of the weld. However, they do affect productivity and decrease the number of weld nuts that can be installed per hour. Hold time is set long enough to permit cooling and solidification of the weld before removing the electrodes. Start with 15 cycles and lengthen if necessary.



SELF-LOCATING PROJECTION WELD NUTS

PERFORMANCE DATA⁽¹⁾

UNIFIED	Type	Thread Code	Test Sheet Material			
			.060" Cold-rolled Steel		.060" 302 Stainless Steel	
			Pushout (lbs.)	Torque-out (in. lbs.)	Pushout (lbs.)	Torque-out (in. lbs.)
WN	440	500	13	N/A	N/A	
	632	640	22	N/A	N/A	
	832	760	33	N/A	N/A	
	032	880	56	N/A	N/A	
	0420	1000	185	N/A	N/A	
WNS	440	N/A	N/A	680	13	
	632	N/A	N/A	800	28	
	832	N/A	N/A	850	45	
	032	N/A	N/A	900	110	
	0420	N/A	N/A	1000	200	

METRIC	Type	Thread Code	Test Sheet Material			
			1.5 mm Cold-rolled Steel		1.5 mm 302 Stainless Steel	
			Pushout (N)	Torque-out (N•m)	Pushout (N)	Torque-out (N•m)
WN	M3	2220	1.4	N/A	N/A	
	M4	3380	3.7	N/A	N/A	
	M5	3910	6.3	N/A	N/A	
	M6	4445	20.9	N/A	N/A	
	M3	N/A	N/A	3020	1.4	
WNS	M4	N/A	N/A	3780	5	
	M5	N/A	N/A	4000	12.4	
	M6	N/A	N/A	4445	22.5	

N/A Not Applicable.

(1) The values reported are averages when all installation specifications and procedures are followed. Performance testing of this product in your application is recommended. We will be happy to provide samples for this purpose.

GUIDES TO BETTER WELDING

Electrodes, weld nuts, and panels must be clean and free of grease, rust, and metal burrs. When welds appear satisfactory on installed nut, but pushout values are low, one or more of the following may be the cause:

- (1) Ram pressure too high.
- (2) Current too low.
- (3) Panel not clean.
- (4) Weld nuts not centered under electrodes.
- (5) Hold time not long enough to allow proper cooling.
- (6) Pressure regulator on welding equipment drifts.

If installed threads are distorted, the following singly or in combination may be the cause:

- (1) Weld time too long.
- (2) Current too high.
- (3) Ram pressure too high.

Should it be impossible to produce a proper weld because weld time starts before electrodes close on the work, shorten the gap between the electrodes so that they take less time to move into position and/or lengthen the squeeze time.

RoHS compliance information can be found on our website.
© 2012 PennEngineering.

PennEngineering®



North America: Danboro, PA USA • E-mail: info@pemnet.com • Tel: +1-215-766-8853 • Fax: +1-215-766-0143 • 800-237-4736 (USA Only)
Europe: Galway, Ireland • E-mail: europe@pemnet.com • Tel: +353-91-751714 • Fax: +353-91-753541
Asia/Pacific: Singapore • E-mail: singapore@pemnet.com • Tel: +65-6-745-0660 • Fax: +65-6-745-2400
 Shanghai, China • E-mail: china@pemnet.com • Tel: +86-21-5868-3688 • Fax: +86-21-5868-3988

Visit our PEMNET™ Resource Center at www.pemnet.com

Technical support e-mail: techsupport@pemnet.com

SETTING GUIDES FOR PEM WELD NUTS IN .030"/0.77 MM TO .063"/1.6 MM SHEETS

UNIFIED	Type	Thread Code	Test Sheet Material					
			Cold-rolled Steel			302 Stainless Steel		
			Electrode (A) Ram Force (lbs.)	Secondary (B) Current Amps ±500	Weld Time (C) Cycles/Sec.	Electrode (A) Ram Force (lbs.)	Secondary (B) Current Amps ±500	Weld Time (C) Cycles/Sec.
WN	440	450-500	17,000	6 / 0.10	N/A	N/A	N/A	
	632	450-500	17,000	6 / 0.10	N/A	N/A	N/A	
	832	450-500	17,000	6 / 0.10	N/A	N/A	N/A	
	032	500-550	18,000	10 / 0.17	N/A	N/A	N/A	
	0420	550-600	20,000	10 / 0.17	N/A	N/A	N/A	
WNS	440	N/A	N/A	N/A	450-500	16,500	6 / 0.10	
	632	N/A	N/A	N/A	450-500	16,500	6 / 0.10	
	832	N/A	N/A	N/A	500-550	16,500	6 / 0.10	
	032	N/A	N/A	N/A	550-600	18,500	6 / 0.10	
	0420	N/A	N/A	N/A	650-700	20,000	6 / 0.10	

METRIC	Type	Thread Code	Test Sheet Material					
			Cold-rolled Steel			302 Stainless Steel		
			Electrode (A) Ram Force (N)	Secondary (B) Current Amps ±500	Weld Time (C) Cycles/Sec.	Electrode (A) Ram Force (N)	Secondary (B) Current Amps ±500	Weld Time (C) Cycles/Sec.
WN	M3	2000-2220	17,000	6 / 0.10	N/A	N/A	N/A	
	M4	2000-2220	17,000	6 / 0.10	N/A	N/A	N/A	
	M5	2220-2440	18,000	10 / 0.17	N/A	N/A	N/A	
	M6	2440-2670	20,000	10 / 0.17	N/A	N/A	N/A	
	M3	N/A	N/A	N/A	2000-2220	16,500	6 / 0.10	
WNS	M4	N/A	N/A	N/A	2220-2440	16,500	6 / 0.10	
	M5	N/A	N/A	N/A	2440-2670	18,500	6 / 0.10	
	M6	N/A	N/A	N/A	2890-3110	20,000	6 / 0.10	

N/A Not Applicable.

(A) **Electrode Force** is the force exerted by the electrodes on the fastener and sheet to clamp them together and ensure good electrical contact. Electrode force also sets the weld nut down flush on the sheet as the projections melt during the welding period. Insufficient electrode force may result in flashing, spitting, burning, spatter, and discoloration. On the other hand, excessive electrode force may flatten the fastener projections before proper welding temperature is reached or may imbed the projections of the cold fastener into the sheet. Excessive electrode force can also distort threads during the weld cycle.

(B) **Secondary Current** determines the heat applied to the PEM weld nut and sheet. Heat is in direct proportion to weld time, resistances of the materials, and the square of the current. Current should not be set so high as to cause flashing or spattering or excessive heat which will distort the threads. Low currents may produce good looking welds but pushout and torque-out strengths will not be satisfactory.

(C) **Timing Cycle** for projection welding comprises four periods. (1) the squeeze time in which the electrodes move into position and develop the required force; (2) the weld time when the current is applied; (3) the hold time while the weld congeals and cools; and (4) the off time for positioning the work for the next weld nut.

NOTE: The setting guides shown in the above charts are for reference only and may differ for your welding equipment.

Specifications subject to change without notice.
See our website for the most current version of this bulletin.