



NEW!

BULLETIN

- KEYHOLE®
- SELF-CLINCHING
- SHEET JOINING
- FASTENERS



SK-F

307

KEYHOLE[®] SELF-CLINCHING, SHEET JOINING FASTENERS

Allows detachable joining of two sheets.

- Clinch feature mounts fastener permanently into metal sheet.
- Unique barrel design allows for quick “panel-on-panel” attachment and detachment.
- Head is flush or sub-flush with one side of metal sheet.
- Can be clinched into blind hole where concealed-head is required.
- Makes horizontal or vertical component mounting possible.

The PEM KEYHOLE[®] sheet joining fastener, Type SKC-F™, is designed so that two sheets can be quickly joined flat against each other and then can be removed from the assembly by simply sliding the sheet sideways and lifting it off.

Typically, several KEYHOLE[®] sheet joining fasteners are used with one standard PEM[®] threaded Type F flush nut which accepts a screw to secure the sheets against any unwanted movement.

Look for the
PEM “dimple”
trademark.



Part Number Designation

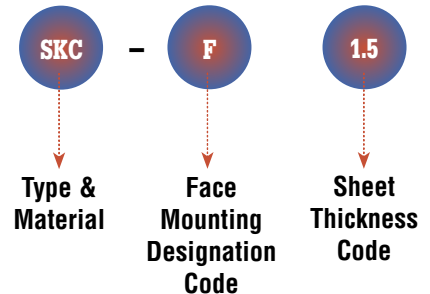

Front view after two sheets are joined together.



Back view. The SKC-F fasteners are sub-flush in sheet.

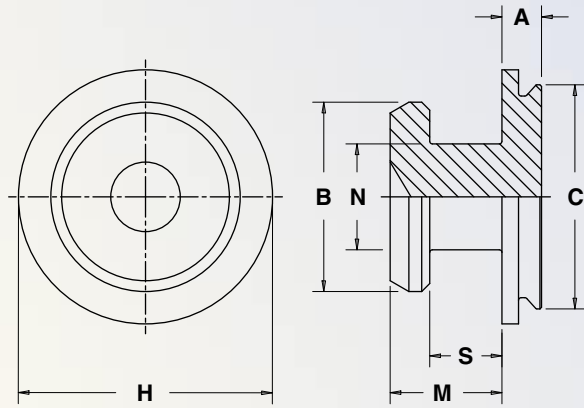

FASTENER MATERIAL:
300 Series Stainless Steel

FINISH:
Passivated and/or tested per ASTM A380

All dimensions are in inches.

UNIFIED	Type	Face Mounting Designation Code	Sheet Thickness Code	A	B	C	H	M	N	S	D
	Stainless Steel			Max.	± .003	Max.	Nom.	Max.	± .003	± .003	Anvil Hole + .003 - .000
	SKC	F	1.5	.039	.177	.212	.237	.108	.099	.068	.184

All dimensions are in millimeters.

METRIC	Type	Face Mounting Designation Code	Sheet Thickness Code	A	B	C	H	M	N	S	D
	Stainless Steel			Max.	± 0.08	Max.	Nom.	Max.	± 0.08	± 0.08	Anvil Hole + 0.08
	SKC	F	1.5	0.99	4.5	5.38	6.02	2.75	2.5	1.72	4.67

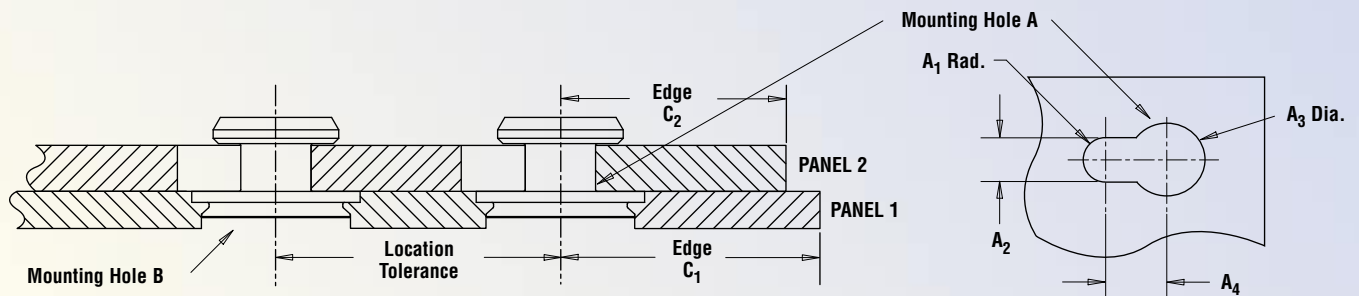

All dimensions are in inches.

UNIFIED	Type	PANEL 1					PANEL 2						
		Bottom Mounting Hole B + .003 - .000	Sheet Hardness Max.	Min. Sheet Thickness (1)	Edge Distance C ₁ Min.	Location Tolerance Max.	Top Mounting Hole A				Material	Thickness Range	Edge Distance C ₂ Min.
							A ₁ Nom.	A ₂ ± .003	A ₃ ± .003	A ₄ Min.			
	SKC-F	.213	HRB 70	.040	0.15	± .005	.059	.118	.197	.148	ANY	.057 - .064	.160

All dimensions are in millimeters.

METRIC	Type	PANEL 1					PANEL 2						
		Bottom Mounting Hole B +0.08	Sheet Hardness Max.	Min. Sheet Thickness (1)	Edge Distance C ₁ Min.	Location Tolerance Max.	Top Mounting Hole A				Material	Thickness Range	Edge Distance C ₂ Min.
							A ₁ Nom.	A ₂ ± 0.08	A ₃ ± 0.08	A ₄ Min.			
	SKC-F	5.41	HRB 70	1.02	3.8	± 0.13	1.5	3	5	3.75	ANY	1.45 - 1.62	4.1

(1) May also be installed into .043"/1.1mm deep blind milled hole in a .062"/1.6mm minimum sheet thickness.

INSTALLATION

Through Hole Installation Procedure

1. Punch or drill properly sized mounting hole in Panel.
2. Place the fastener into anvil hole as shown in the drawing to the right.
3. Place the panel over the shank of the fastener.
4. With the punch and anvil surfaces parallel, apply only enough squeezing force until flange is flush with panel.

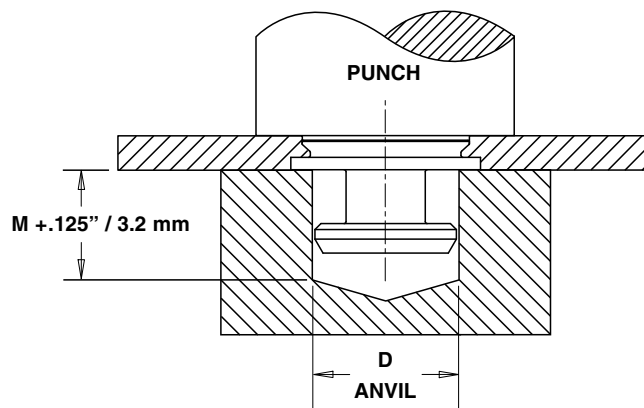

Blind Hole Installation Procedure

1. Mill a blind hole to .043" / 1.1mm deep.
2. Place the fastener into anvil hole as shown in the drawing to the right.
3. Place the panel over the shank of the fastener.
4. With the punch and anvil surfaces parallel, apply only enough squeezing force until flange is flush with panel.

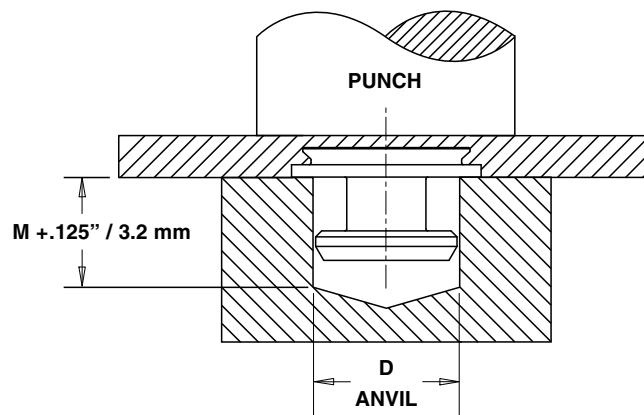

PERFORMANCE DATA⁽¹⁾

		.060" 5052-H34 Aluminum			.060" Cold-Rolled Steel		
UNIFIED	Type	Installation (lbs.)	Pushout (lbs.)	Side-Load Force Max. (lbs.)	Installation (lbs.)	Pushout (lbs.)	Side-Load Force Max. (lbs.)
		SKC-F	1100	120	120	2100	160

		1.52 mm 5052-H34 Aluminum			1.52 mm Cold-Rolled Steel		
METRIC	Type	Installation (kN)	Pushout (N)	Side-Load Force Max. (N)	Installation (kN)	Pushout (N)	Side-Load Force Max. (N)
		SKC-F	4.9	533	533	9.3	711

(1) The installation and pushout values reported are averages when all installation specifications and procedures are followed. Variations in mounting hole size, panel material and installation procedure will affect this data. Performance testing of this product in your application is recommended. We will be happy to provide samples for this purpose.

RoHS compliance information can be found on our website.

Specifications subject to change without notice.
Check our website for the most current version of this bulletin.

PennEngineering®



North America: Danboro, PA 18916 USA • E-mail: info@pemnet.com • Tel: +1-215-766-8853 • Fax: +1-215-766-0143 • 800-237-4736 (USA Only)
U.K. And Europe: Doncaster, England • E-mail: uk@pemnet.com Tel: +44 (0)1302 765700 • Fax: +44 (0)1302 367580
Asia/Pacific: Singapore • E-mail: singapore@pemnet.com • Tel: +65-6-745-0660 • Fax: +65-6-745-2400
Shanghai, China • E-mail: china@pemnet.com • Tel: +86-21-5868-3688 • Fax: +86-21-5868-3988

Visit our PEMNET™ Resource Center at www.pemnet.com

CAGE-46384