



SERIES P3™

PNEUMATIC HAND PRESS

The PEMSERTER® Series P3 fastener installation press is a portable power hand tool weighing only 4.6 kg. that can develop a squeezing force of 22.2kN.

With the PEMSERTER Series P3 press, you can easily install self-clinching nuts and studs in metric or unified sizes. The press kit contains punches and anvils to install nuts (S, CLS, and CLA) ranging from M2 thru M4 thread sizes and studs (FH, FHS, and FHA up to 12mm in length) ranging from M2.5 thru M4 thread sizes.



Specifications

Ram Force	Up to 22.2 kN
Pressure System Type	Pneumatic
Air Requirements*	6 to 7 BAR
Throat Depth	7.6 cm
Length	40.6 cm
Yoke Depth	15.8 cm
Weight	4.6 kg

*1 psi = 0.07 bar. 1 bar = 14.5 psi.

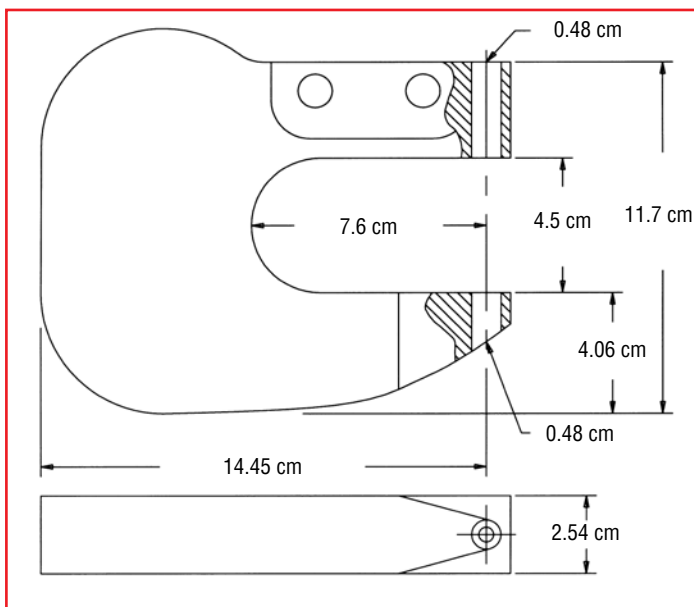

Features and Benefits

- ♦ Pneumatic power for consistency and simple operation. Requires shop air only.
- ♦ Trigger controlled safety.
- ♦ Snap-in tooling changeover.
- ♦ Press includes metric or unified tooling.
- ♦ Can be bench-mounted. Back side of yoke has two predrilled and tapped holes for bench mounting. Mounting bracket hardware included.
- ♦ One-year parts warranty.

Specifications subject to change without notice.
Check our website for the most current version of this bulletin.

© 2008, PennEngineering

PennEngineering®



North America: Danboro, PA USA • E-mail: info@pemnet.com • Tel: +1-215-766-8853 • Fax: +1-215-766-0143 • 800-237-4736 (USA Only)
Europe: Galway, Ireland • E-mail: europe@pemnet.com • Tel: +353-91-751714 • Fax: +353-91-753541
Asia/Pacific: Singapore • E-mail: singapore@pemnet.com • Tel: +65-6-745-0660 • Fax: +65-6-745-2400
 Shanghai, China • E-mail: china@pemnet.com • Tel: +86-21-5868-3688 • Fax: +86-21-5868-3988

Visit our PEMNET™ Resource Center at www.pemnet.com

PSP3_MM-408
Rev. 211

PEMSERTER[®] MICRO-MATE[®] HAND TOOL

The PEMSERTER[®] MICRO-MATE[®] press is a versatile hand tool weighing only 1.25 kg that can develop a squeezing force of 1,134 kg.

The press kit contains one hand tool, one flat punch, seven punches and dies, one punch adapter bushing, one edge-depth guide, five fastener anvils and a storage case. The kit installs nut sizes M2 to M5.

Features and Benefits

- ♦ Equipped with punches and dies to punch fastener mounting holes in metal sheets.
- ♦ Changes to a flat punch and recessed anvil to easily install metric or unified self-clinching nuts.
- ♦ Ideal for prototype shops or short production runs.
- ♦ One-year parts warranty.



*Specifications subject to change without notice.
Check our website for the most current version of this bulletin.*

© 2008, PennEngineering

PennEngineering[®]



North America: Danboro, PA USA • E-mail: info@pemnet.com • Tel: +1-215-766-8853 • Fax: +1-215-766-0143 • 800-237-4736 (USA Only)
Europe: Galway, Ireland • E-mail: europe@pemnet.com • Tel: +353-91-751714 • Fax: +353-91-753541
Asia/Pacific: Singapore • E-mail: singapore@pemnet.com • Tel: +65-6-745-0660 • Fax: +65-6-745-2400
Shanghai, China • E-mail: china@pemnet.com • Tel: +86-21-5868-3688 • Fax: +86-21-5868-3988

Visit our PEMNET[™] Resource Center at www.pemnet.com

PSP3_MM-408
Rev. 211